

Close-coupled in-situ multi-gas IR-GFC Analyzer

PROCESS & EMISSIONS MONITORING SYSTEMS

One single analyzer for the measurement of:
HCl, NO, NO₂ (NO_x), SO₂, CO, CO₂,
HC, CH₄ (TOC), HF, N₂O, O₂...

SPECIFIC FEATURES:

- Complete CEMS in one cabinet: combines infrared analyzer, sample conditioning system & probe into one device
- Fast, continuous and simultaneous measurement of up to 10 gases at the sampling location
- Robust and reliable short extractive analyzer with built-in permeation sample drying system for the measurement of wet and corrosive sample
- Highly accurate; excellent calibration stability with automatic optical check
- Ease of installation: single stack entry, on-stack or close-coupled therefore reducing costs
- Fast response time, with automatic cross interference correction
- Robust remote control and display functions
- Graphic LCD screen with real time synoptic
- Intrinsic security with on-board residual H₂O measurement
- On-board paramagnetic cell for long term O₂ monitoring
- Heated probe in different materials and lengths to suit the application
- Built in a stainless steel tight box enclosure for safe outdoor installations
- External signal input for up to 5 additional measurements (flow rate, pressure, gas temperature...) or any other analog input

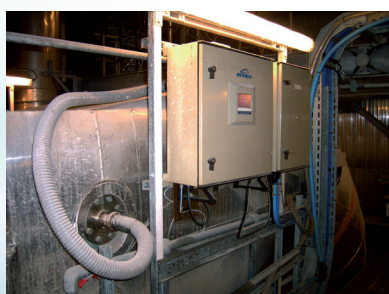

On-stack or close-coupled installation

MAIN APPLICATIONS:

- > Industrial Boilers and Furnaces, Chemical and Petrochemical Plants
- > Incineration, Co-generation, Gas Turbines, Power Plants
- > Process Control, Pre/post Scrubber Measurements
- > Coal / Oil / Gas Fired Combustion Monitoring
- > CHP Combustion Monitoring

COMPLIANCE WITH:

EU Regulation IED (2000/76/EC (WID) / 2001/80/EC (LCPD) / MCPD directives) and US EPA (40 CFR 60 & 75)



U.S. EPA APPROVED
40 CFR 60 ET 75



M-CERTS CERTIFIED
EN 15267-3

QAL 1
EN 15267-3

QAL 3
EN 15267-3

In-situ multi-gas IR GFC analyzer **MIR IS**

Lowest / Highest available ranges

NO_x	0-200 / 5 000
CO	0-75 / 10 000
CO₂	0-10 / 100 %
SO₂	0-75 / 5 000
N₂O	0-20 / 1 000
HCl	0-15 / 5 000
HF	0-20 / 300
CH₄	0-10 / 1 000
TOC	0-50 / 5 000
O₂	0-10 / 25 %

Expressed in mg/m³ or % when indicated.
Other ranges available on request

PRINCIPLE OF OPERATION:

Developed specifically for CEMS and process online monitoring, the MIR IS in-situ multi-gas CEM analyzer is a compact short-extractive system based on our well-known MIR 9000 analyzer. Providing high performance, sensitivity and accurate measurements on a large number of gas parameters, the MIR IS offers very fast response time (less than 40ms). It uses the Infra-Red Gas Filter Correlation principle, a well-established method to reduce cross interferences between compounds and therefore providing measures with high accuracy and repeatability.

The MIR IS uses a 16-position rotating correlation wheel with on-board interferential gas filters, allowing simultaneous multi-gas measurement. The optical bench includes a low volume gas cell with a 12 m optical path length and incorporates aspheric and aberration correcting mirrors. A built-in paramagnetic sensor can be optionally added for oxygen measurement, and the analyzer accepts and displays additional external inputs (flow, temperature, pressure, etc.).

The powerful embedded software integrates and compiles infrared detector signals and calculates concentration of all compounds simultaneously. All measurements are available in graphical and tabular formats, but also on digital (RS232/485 & TCP -IP) and analogue outputs (mA or V configurable). A large LCD screen with keypad powered by user-friendly and easy to configure software with diagnostic functions allows easy user access. USB interface allows easy and fast software upgrades and data extraction possibilities.

MAIN OPTIONS:

- O₂ measurement (paramagnetic cell)
- TIG: automatic span gas injection module
- Installation accessories
(Sample probe and line, Frame, Hanging devices...)
- Gas flow rate, velocity, temperature and pressure measurements
- **Certified WEX® advanced CEMS data management & supervision software**
- Probe length (mm): 500/700/1000/1500

TECHNICAL SPECIFICATIONS

Display	LCD graphic display
Repeatability	± 2% of full scale (F.S.)
Zero drift	± 2% of F.S. /30 days
Span drift	± 2% of F.S. /30 days
Linearity	± 1% of F.S.
Lowest detectable limit	± 2% of F.S.
Average value	programmable
Data storage	last 3000 averages
Communication port	RS232/RS422, Ethernet
Dimensions (mm)	200x600x600 (DxWxH)
Weight	50 kg approximately
Power	115/230 VAC, 50/60 Hz, 700 VA
Operating temperature	-15°C to +50°C
Housing	stainless steel IP 65 tight box
Instrument air	7Nm ³ /h, 5 bars

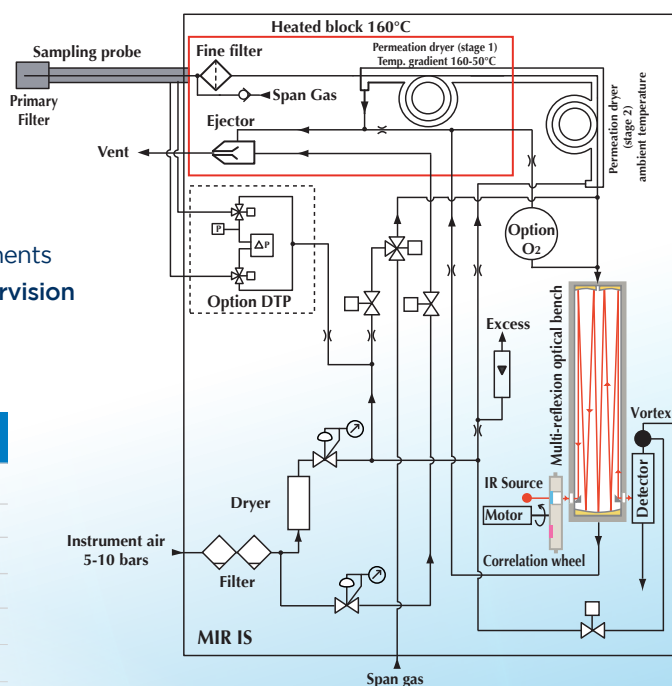

Correlation wheel equipped with optical filter and gas cells

MIR IS is the unique AMS on CEMS market offering an accurate multi-gas analysis solution (up to 10 gases including HCl and HF + O₂ as an option) integrating optionally flue gas temperature, flow and pressure measurements on a single sampling probe, means a single sampling point.

SAMPLING IS CD IN-SITU, COLD DRY EXTRACTIVE



ENVEA (Headquarters)
111 Bd Robespierre - CS 80004
78300 Poissy / Cedex 4 - FRANCE
+33(0) 1 39 22 38 00
info@envea.global



Visit us on:
www.envea.global

